



GS Model GS12D

Standby Power Range: 12.3 - 13.0 kW 60Hz

Prime Power Range: 10.6 - 11.7 kW 60Hz

Generator Set Technical Data Sheet

GS Series Alpha Diesel Series

Genset Model	Alternator Brand	Hz	Standby kW		Prime kW	
			3 ph	1 ph	3 ph	1 ph
GS12D-LM	Mecc Alte	60	13.0	12.3	11.7	11.1
GS12D-LN	Newage	60	12.2	11.7	11.1	10.6
GS12D-LM	Mecc Alte	50	10.3	9.7	9.2	8.7
GS12D-LN	Newage	50	10.0	9.7	9.1	8.8

Rating Conditions: The standard ratings assume an air inlet temperature of 77°F (25°C), altitude 500 feet (152 meters) above sea level, and relative humidity of 60%.

Standby Power: Assumes a continuous variable load while utility power is interrupted. No overload is available.

Prime Power: Continuous power rating with 10% overload available for 1 hour in 12 hours of operation.

GS Series Open Set Shown



Standard Features and Options (* consult with factory for full list of options)

Standard Features

- ◆ Lister Petter Alpha engine
- ◆ Full flow fuel and oil filters
- ◆ Self-priming fuel system
- ◆ Mechanical governor
- ◆ 12 volt starter and alternator
- ◆ Belt fan guard
- ◆ Oil drain
- ◆ Industrial silencer
- ◆ Fuel control solenoid
- ◆ Dry type air-cleaner
- ◆ Fabricated steel skid base
- ◆ Powder-coated Hawkpower silver
- ◆ Vibration isolator mounts
- ◆ Digital auto-start controls with safety shut-down and fault Indication
- ◆ Battery hold down rack and cables
- ◆ 12-wire re-connectable brushless Mecc Alte alternator
- ◆ Operator handbook
- ◆ Fuel lift pump
- ◆ Based mounted radiator cowling

Optional items*

- ◆ Weather protective canopy
- ◆ Full sound attenuated enclosure
- ◆ Complete AC/DC instrumentation
- ◆ Variety of fuel tanks including UL142
- ◆ Emergency stop-switch
- ◆ Industrial & critical mufflers
- ◆ Main-line circuit breaker
- ◆ Auto-battery charger
- ◆ Newage alternator
- ◆ Electronic governor
- ◆ Heavy-duty air-cleaner

Benefits of choosing a Lister Petter Generator Set

The Lister Petter GS series of generator sets are designed and assembled in our own facility. Drawing from several decades of generator set assembly experience our customers receive generators that are fully tested before shipment, built to all codes and standards, and provide stable, clean electrical power with a very steady voltage and frequency output. The Alpha series of engines are extensively used in generator sets, with tens of thousands of installations, for a proven track record in power generation demonstrating high reliability, longer maintenance intervals and a lower cost of ownership. For after-market support our customers can rely on a comprehensive network of product service centers, with single source product support and full parts availability. A wide range of options are available.

Generator Models GS12D-LM & GS12D-LN Specification

Power Ratings

Model number	Voltage range	Ph	pf	Hz	Standby Power			Prime Power		
					kW	kVA	Amps	kW	kVA	Amps
GS12D-LM	120/240	1	1.0	60	12.3	12.3	51.3	11.1	11.1	46.3
	120/208	3	0.8	60	13.0	16.3	36.1	11.7	14.6	32.5
	120/240	3	0.8	60	12.9	16.1	31.1	11.7	14.6	28.2
	277/480	3	0.8	60	13.0	16.3	15.7	11.7	14.6	14.1
GS12D-LN	120/240	1	1.0	60	11.7	11.7	48.8	10.6	10.6	44.2
	120/208	3	0.8	60	12.2	15.3	33.9	11.1	13.9	30.9
	120/240	3	0.8	60	12.2	15.3	29.4	11.1	13.9	26.7
	277/480	3	0.8	60	12.2	15.3	14.7	11.1	13.9	13.4

Application Air, Exhaust and Cooling Requirements US (Metric) @ 60Hz

Cooling data and requirements	Standby Rating	Prime Power Rating
Total coolant including radiator US gal (liters)	1.84 (7.0)	1.84 (7.0)
Coolant flow rate US gal/min (Liters/min)	10.8 (41)	10.8 (41)
Heat rejection to coolant Btu/min (kW)	658 (11.5)	599 (10.5)
Heat rejection to surroundings Btu/min (kW)	219 (3.8)	199 (3.5)
Application Air-Flow Requirements		
Maximum air-restriction inH ² O (mmH ² O)	10 (254)	10 (254)
Radiator cooling-air cfm (m ³ /min)	2119 (60)	2119 (60)
Combustion-air cfm (m ³ /min)	37.7 (1.07)	37.7 (1.07)
MeccAlte alternator cooling-air cfm (m ³ /min)	205 (5.8)	205 (5.8)
Newage alternator cooling-air cfm (m ³ /min)	252 (7.14)	252 (7.14)
Exhaust Gas Data		
Exhaust gas flow cfm (m ³ /min)	105.3 (3.0)	95.8 (2.7)
Maximum back pressure inH ² O (mmH ² O)	20 (508)	20 (508)
Exhaust temperature °F (°C)	950 (510)	865 (464)

Fuel, Lube Oil and Ratings Data @ 60Hz

Recommended oil change @ ambient temp.	Up to 95°F (35°)	Above 95°F (35°)
Hours interval between oil changes	250	250
Fuel consumption US gal/Hr (Liters/Hr)	Standby Rating	Prime Power Rating
100%	1.0 (3.8)	0.96 (3.65)
75%	0.8 (3.0)	0.72 (2.74)
50%	0.53 (2.0)	0.48 (1.83)
De-rating factors	Altitude	Temperature
Ratings are calculated at normal temperatures and pressures, with an ambient less than 77°F and altitude less than 325ft above sea level	4.5% for every 1000ft (300m) above 325ft (150m)	2.5% for every 9°F (5°C) above 77°F (25°C)
Humidity derate up to a maximum of 10% depending on the ambient temperature		

* Noise Data dB(A) @ 7 meters (8 position average)

Configuration of set	Open	Enclosed	Sound attenuated
Noise rating: dB(A)	79.6	76.9	69.4

* With critical muffler option

Engine and Alternator Specifications

Engine

Basic Engine Data		Valve Train	
Manufacturer	Lister Petter	Lifter type	Hydraulic
Alpha model naturally-aspirated	LPW3	Emissions	
Cylinders	3	EPA Certified	No
Displacement Cu.in (Liters)	85.1 (1.4)	Engine Governor	
Bore inches (mm)	3.38 (86.0)	Standard mechanical system	Hz no load to full load 5.0%
Stroke inches (mm)	3.15 (80.0)	Optional electronic system	Hz no load to full load 0.5%
Compressions ratio	18.5:1	Steady regulation mechanical	±0.5%
Number of main bearings	4	Steady regulation electronic	±0.25%
Connection rods	3	Cooling System	
Piston material	Aluminium alloy	Type of system	Pressurized
Cylinder head material	Cast iron	Water pump	Sealed
Oil capacity gals (liters)	1.0 (3.79)	Type of fan	5 blade Pusher
Engine Electrical System		Fuel System	
Glow plugs	No	Fuel	#2 Diesel Fuel
Battery charge alternator	55 amp	Fuel injection pump	Bosche
Starter motor	12V	Fuel pump type	Plunger Cam Drive
Recommended lead acid battery	Group 34 850 CCA	Combustion	Direct
Ground polarity	Negative	Firing order	1-2-3

Alternator

Basic Alternator Data		Excitation System	
Type	4 - pole	Coupling arrangement	Close
Rotor insulation	Class "H"	Load capacity (standby)	110%
Stator insulation	Class "H"	Load capacity (prime)	100%
Total harmonic factor	Less than 2%	Brushless	AVR
Telephone influence factor (TIF)	Less than 50	Volts change 100% load step	Under 3% (¼ sec)
Alternator cooling	Self ventilating	Voltage regulation	2% all loads to 100%
Bearings	Single	Temperature rise	125°C

Alternator Features

◆ The alternators are dipped in varnish and have epoxy-coated windings.

◆ The alternators are designed to meet the temperature rise standards of class "H" insulation. The windings have a 2/3 pitch in order to reduce the harmonic content of voltage.

◆ MeccAlte motor starting is 3 times running kVA and Newage regulated is 2 times running KVA.

◆ Four pole, revolving field alternator, close-coupled to the engine by means of generator flange bolting directly to flywheel housing. Drive is by flexible disc.

◆ All Lister Petter gensets are fully factory tested, a test sheet is available for each set. A performance test is made by increasing load steps up to 110% of continuous rating.

◆ The alternator complies with VDE0530, BS4999 or 5000 and is CSA approved. The alternator is self ventilated drip-proof construction. The standard of enclosure protection is IP21 or IP23.

Note: The information in this data sheet is of a general nature and does not form part of any contract and/or warranty. We have made efforts to ensure that the information is accurate but reserve the right to amend the specification and information without notice or any obligation or liability. The set illustrated is not necessarily the standard build.

Alpha GS Series Control Panel Options



'DA' Standard Auto Start Panel

Standard 'DA' Control Panel: This control comes complete as a manual or auto start control with hour meter in a vibration isolated cabinet. When in "Auto" position a simple switch closure of any kind will signal the set to start. Controls provide safety shutdown protection, with LED indication for low oil pressure, high temperature, over/under speed and over crank fault after three attempts to start. Low battery voltage will have a warning. It comes standard with two configurable input/outputs.



'CN' Auto Start Panel with LCD

Optional 'CN' Control Panel: This control comes complete as a manual or auto start in a vibration isolated cabinet. When B+ is available a simple switch closure of any kind will signal the set to start. In addition to LED's described above with the DA control it includes a LCD that allows monitoring oil pressure, temperature, D/C voltage, hour meter, A/C alternator output voltage, speed/hertz and amps. It comes standard with three inputs and two outputs that are configurable. Some programming can be made from the front of the control but most come factory preset. Special programming is available at additional charge.

Alpha GS Series Dimensions and Weights

Model number GS12D																			
Dimension	Unpacked dimensions						Shipping dimensions						Weights (with packing options)						
	Open		Enclosed		Attenuated		Open		Enclosed		Attenuated		Packing lbs (kg)	Open		Enclosed		Attenuated	
	ins	cm	ins	cm	ins	cm	ins	cm	ins	cm	ins	cm	None	640	(290)	730	(331)	810	(367)
"H" height	39.8	101	41.0	104	41.0	104	45.8	116	47.2	120	47.2	120	Pallet Only	690	(313)	780	(354)	860	(390)
"W" width	28.3	72	28.3	72	28.3	72	35	89	35	89	35	89	Open Crate	765	(347)	855	(388)	935	(424)
"L" length	58.5	149	58.5	149	78.0	198	80	203	80	203	80	203	Closed Crate	810	(367)	890	(404)	970	(440)

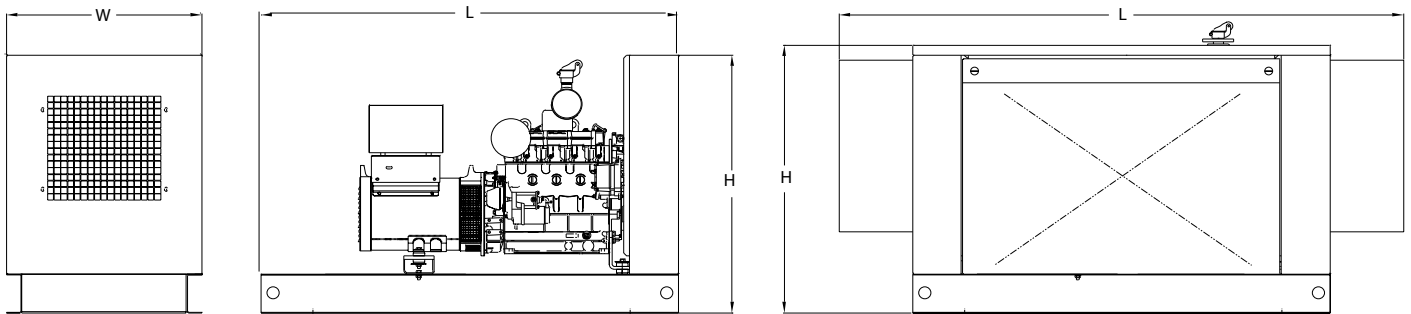

For more information contact:

